

# SEA HYPERSORT COLOR SORTER

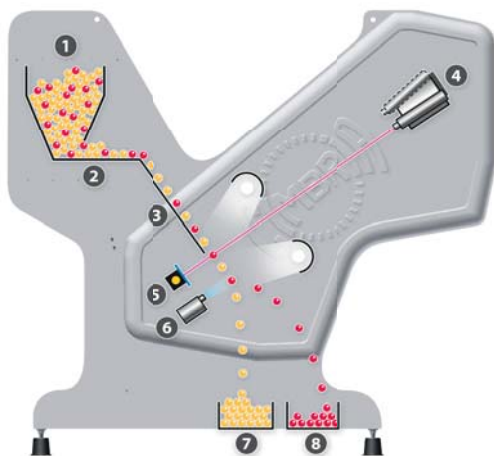

## PROCESS

- 1 In-feed hopper
  - 2 Vibrating plate
  - 3 Feeding chute
  - 4 Inspection system (ultimate RGB Full-Color + Hyperspectral NIR cameras)
  - 5 Lighting system & background
  - 6 Ejectors
  - 7 Selected product
  - 8 Reject
- For grinded and flakes plastic recycling
  - Configurations and simultaneous resorting
  - Ideal to sort materials from 2 mm to 50 mm



## TECHNICAL CHARACTERISTICS:

### EXAGON USER INTERFACE

- 15" color touch screen with capacitive feature for perfect visibility in low light conditions
- Intuitive graphics and multilingual interface
- It allows to directly control the product and modify the recipes in an easy and fast way

- EXAGON main information and functions:



- Machine status (vibrators and sensitivity on/off per section) through its synoptic
- Recipes (up to 200 stored in the machine)
- Level sensor (product control inside the hopper)
- Real-time statistics (e.g. number of rejects per second or per family defects, etc.)
- Alarms and smart explanation for the restoration of the machine function in case of anomalies
- Total and partial hour counter

## OPTICAL SYSTEM

- NIR (SWIR) Infrared hyperspectral cameras recognize the differences of materials according to the specific and unique spectral characteristics. Combined with the RGB Full-Color cameras, they identify the product by color and polymer
- Ultimate 4096 pixels cameras. The system works in the visible spectrum looking almost like the human eye
- Additional NIR and/or InGaAs cameras
- Scan rate: up to 20.000 scan./s
- Optical resolution: 0,06 mm
- The software can control 16 families of defects
- Shape-sizing integrated in the system
- Defect size control and adjustment
- LED lighting and active background

## EXPULSION SYSTEM

- M version: n. 126 ejectors
- L version: n. 252 ejectors
- Ejectors working speed up to 1.000 cycles/s, guaranteed up to 2 billion cycles

# SEA HYPERSORT COLOR SORTER

## ELECTRICAL SYSTEM

- Organized in electronic boards of easy substitution and of latest technology
- Self-control functions (self-diagnosis and self-calibration) guarantee excellent operational stability
- Ethernet connection allows real-time monitoring and web-based remote assistance

## MECHANICS

- Available in medium (M) and large (L) versions that can be divided into 2 different sections according to the demands and different production capacities
- Pressurization and airtight optical boxes prevent dust entering
- Automatic cleaning system
- The cooling system grants the ideal temperature inside the optical boxes
- Pre-arrangement for the aspiration system connection

Leave at least 1 meter of free space around the machine.  
Keep the machine far from direct and strong light sources.

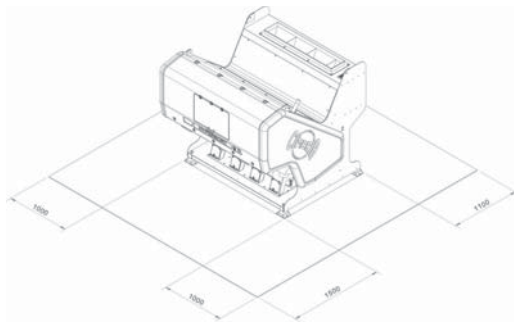

## POSSIBLE OPTICAL CONFIGURATIONS

Model	Standard configuration	High resolution configuration
HYPERSORT M	n.1 HYPER SWIR camera + n.1 RGB Full-Color camera	n.2 HYPER SWIR cameras + n.1 RGB Full-Color camera
HYPERSORT L	n.2 HYPER SWIR cameras + n.2 RGB Full-Color cameras	n.4 HYPER SWIR cameras + n.2 RGB Full-Color cameras



## TECHNICAL DATA

- Standard color: white RAL 9010
- Working environment temperature: between +3°C and +35°C
- Liquid impermeability and dust protection IP 55
- CE conformity certification
- 2006/42/CE on machinery safety
- 2014/30/CE on Electromagnetic Compatibility
- Compatibility with UL and CSA standards
- Compatibility with ATEX standards (on demand)

## EXTERNAL EQUIPMENT REQUIRED FOR THE SORTER OPERATION:

For the correct sorter operation, the user must provide and install:

- 230 V - 50 Hz Power supply
- Proper voltage stabilizer (strictly necessary)
- Pneumatic system including: rotary compressor, tank, dehumidifier class ISO 8573-1:2010 [5:3:3] ANSI/ISA-7.0.01-1996 with dew temperature -20°C (-4°F) (strictly necessary)
- 1" minimum diameter air supply tube
- Support frame of the machine
- Additional loading and unloading hoppers
- Product conveyors systems
- Fast internet connection

						
		HYPERSORT M Standard Resolution	HYPERSORT MH High Resolution	HYPERSORT L Standard Resolution	HYPERSORT LH High Resolution	
In-feeder standard		included	included	included	included	
Chute width	mm	620	620	1240	1240	
No. Hyperspectral NIR camera		1	2	2	2	
No. RGB Full-Color camera		1	1	2	2	
No. ejectors		126	126	252	252	
Compressed air consumption (max. value at 6 bar)	l/s	45	45	70	70	
Compressed air connection		1"				
Power supply/frequency		230 / 50 - 1 Ph ( L + N + PE )				
Power absorption (max. value)		kVA	2.2	2.7	3.0	3.5
Machine dimensions	Width	mm	1960	1960	1960	1960
	Depth	mm	2050	2050	2050	2050
	Height	mm	1780	1780	1780	1780
Weight		kg	1400	1400	1500	1500