

# SCREW CONVEYOR TYPE CO

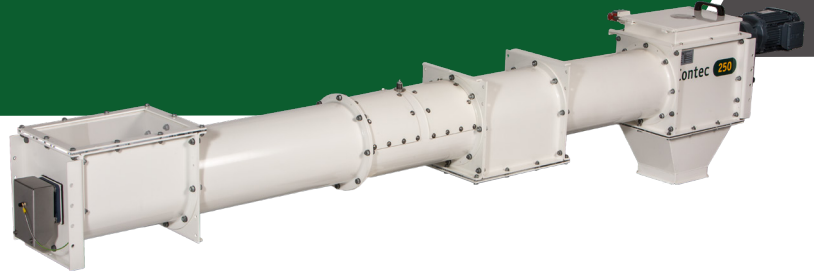

**GENERAL**

Brand Tube conveyor  
 Model CO  
 Capacity range 15-475 m<sup>3</sup>/h  
 Application Efficient conveying of dry bulk materials

**Design**

The tubular conveyor type CO is designed for efficient and reliable handling of powders and granular bulk materials in industrial plants. It is dust-proof modular steel construction with tube sections of 2 m. and inner conveyors of 4-6 m./sections.

Supported by hang-bearings every 4 m. for horizontal transport and every 6 m. for vertical transport. The design of the support bearings all wearing parts to be changed easily. The standard support bearing material is beech wood, alternatively plastic, bronze or ball bearings.

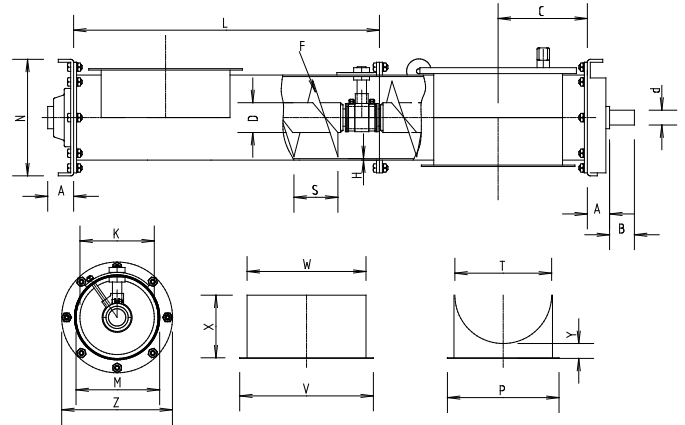

**Conveyor type CO - DIMENSIONS**

	CO150	CO200	CO250	CO300	CO350	CO400	CO450	CO500
A	53	53	53	78	80	90	90	90
B	55	55	55	72	68	108	120	120
C	200	200	250	250	250	275	325	350
D	63.5x5	88.9x4.9	88.9x4.9	88.9x4.9	88.9x4.9	114.5x5.4	114.5x5.4	114.5x5.4
d	35	35	35	60	60	80	80	80
F*	150 x 4/2	200 x 4/2	250 x 4/2	300 x 4/2	350 x 4/2			
F^						400x5	450x5	500x5
H	3	3	3	3	3	4	4	4
K	150	200	250	300	350	400	450	500
L	2 000	2 000	2 000	2 000	2 000	2 000	2 000	2 000
M	116	216	266	320	370	420	470	520
N	240	290	340	394	474	526	576	628
P	228	278	328	382	442	496	546	600
S	130	175	225	260	305	315	335	390
T	178	228	278	332	382	436	468	540
V	350	350	450	450	510	560	610	660
W	300	300	400	400	450	500	550	600
X	99	124	149	176	201	228	253	280
Y	13	13	13	13	13	14	14	15
Z	224	274	324	378	458	510	560	612
Basic add.	30	70	50	75	95	135	155	175
Kg/m	30	40	45	50	130	170	195	215

All dimensions are in mm. Weights are excl. gear, motor and coupling

**Conveyor type CO - CAPACITY**

CAPACITY for every 5 degrees inclination, the capacity will drop 10%

Material	Grain		Flour		Coarser products		
	Type	Max. rpm.	m <sup>3</sup> /h with 50% filling and max. rpm.	Max. rpm.	m <sup>3</sup> /h with 40% filling and max. rpm.	Max. rpm.	m <sup>3</sup> /h with 30% filling and max. rpm.
CO 200		240	32	120	13	95	7.3
CO 300		160	80	80	32	65	19.5
CO 400		140	153	70	62	55	36.0
CO 500		115	250	60	104	45	59.0

**Capacity descent by slide put conveyor**

Slope angle in degrees	0	15	30	45	60	75	90
App. capacity in % as regards to horizontal	100	80	70	60	50	40	30

Note for max. filling:  
 On conveyors without bearings, one can obtain a filling of app. 80% on certain products



**CONVEYING**  
**SCREW CONVEYOR**  
**TYPE CO**

Recommended effect diagrams for horizontal conveyor in standard version:

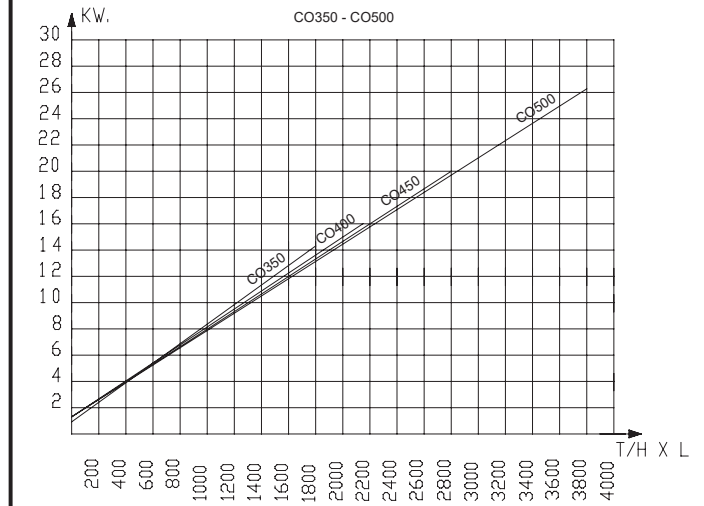
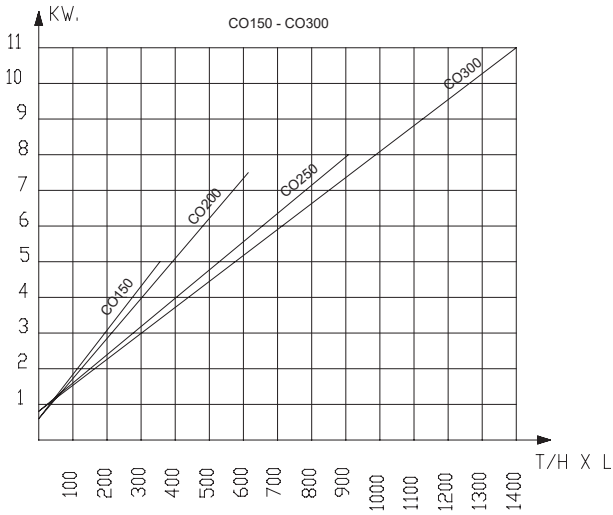

Flights can be delivered as right-hand or left-hand. As standard, the conveyors are delivered as right-hand.

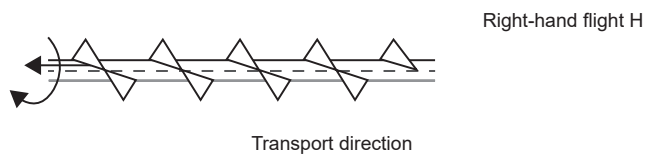
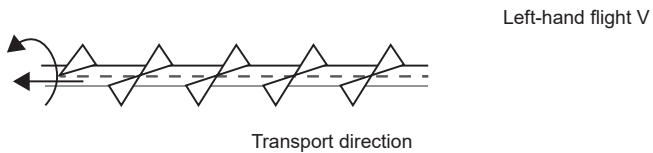

The diagrams are valid for light powder products etc., effect factor 2.3. At strongly wearing material such as sand, salt etc. effect factor 3-6 is used. The diagrams are not valid for special conveyors and extraction conveyors under silos. T/H=Tonne/hour - L=Length in meter

Examples of effect factor:

Effect factor 3.0 – Sawdust

Effect factor 3.5 – Coconut deposits

Effect factor 4.0 – Bone meal, cement, gypsum, earth, clay.

Effect factor 5.0 – Fertiliser

Effect factor 6.0 – Ashes, cinder, sand, salt

Effect addition for oblique conveyor

$$kW = \frac{t/h \times \text{lifting height} \times 1.15}{329}$$

329