

Air-Lock Valve TYPE QDG-92

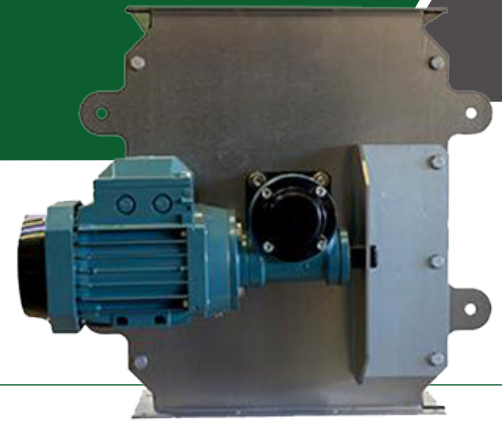

Application

CIMBRIA's air-lock valve type QDG-92 is used for discharge of dust and other separated particles from systems working with vacuum or pressure. It is dust proof and is used as a pressure block between a cyclone and a dust collecting bag.

In connection with CIMBRIA's dust collecting cyclofans the air-lock valve is mounted between the bottom outlet of the mini cyclone and the dust bag, where it ensures a uniform and continuous discharge of dust and other particles, and at the same time minimises the air escaping through the outlet into the dust bag.

Design

The air-lock valve is manufactured from galvanised plate and is complete with a 300 (12") steel roller with 6 radial vanes of oil-resistant rubber. The rotor is suspended in ball bearings and the gear motor is mounted on the extended axle of the rotor.

The air-lock valve is lubricated for life is designed for continuous operation.

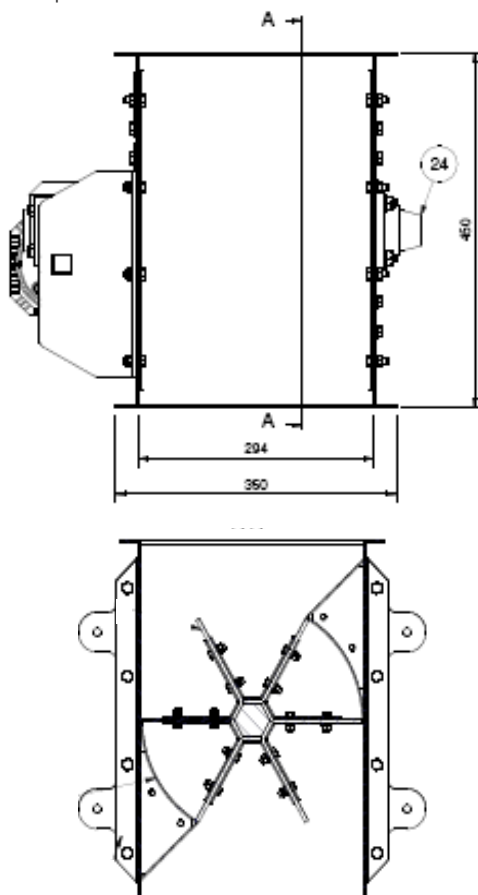
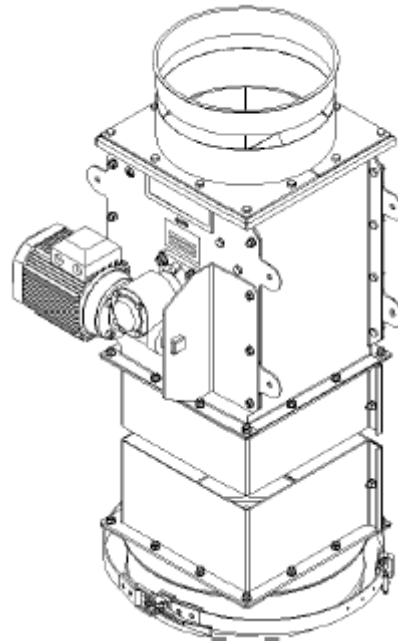

Installation

The air-lock valve is designed for mounting directly on the Cimbría Q-30 spouting system.

Technical data

Capacity	19.2 litres per RPM 48 m ³ per hour
Motor Power	0.37 kW (0.5 HK) 1.3 Amp, 400 V
Revolutions	1 400/40 RPM/min.
Gear Box	BJ 01/M4-30/85 ø20
Approx. weight with motor	45.8 kg
Approx. volume incl. sea-worthy packing	0.17 m ³
Inlet size (square)	300 mm (12") Q-30