

Air-Lock Valve TYPE QDG-52

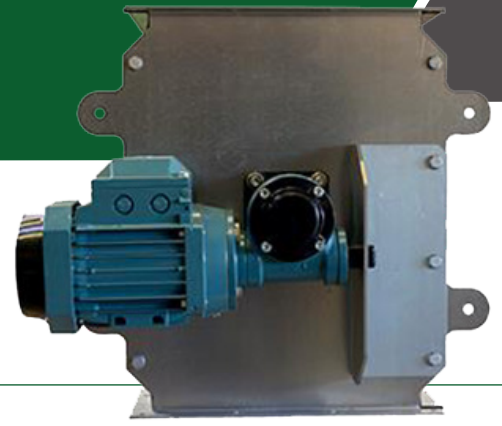

Application

CIMBRIA's air-lock valve type QDG-52 is used for discharge of dust and other separated particles from systems working with vacuum or pressure. It is dust proof and is used as a pressure block between a cyclone and a dust collecting bag.

In connection with CIMBRIA's dust collecting cyclofans the air-lock valve is mounted between the bottom outlet of the mini cyclone and the dust bag, where it ensures a uniform and continuous discharge of dust and other particles, and at the same time minimises the air escaping through the outlet into the dust bag.

Design

The air-lock valve is manufactured from galvanised plate and is complete with a 200 mm (8") steel roller with 6 radial rubber vanes on the shaft. The rotor is carried by ball bearings and its speed does not normally exceed 40 RPMs. The air-lock valve is lubricated for life and is designed for continuous operation.

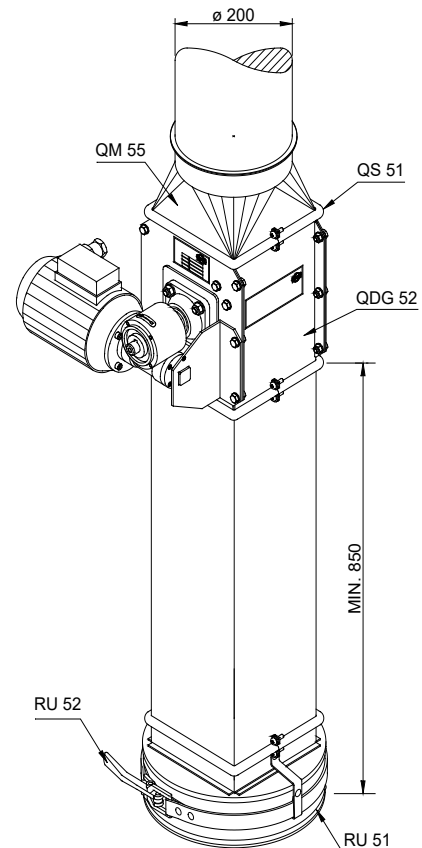
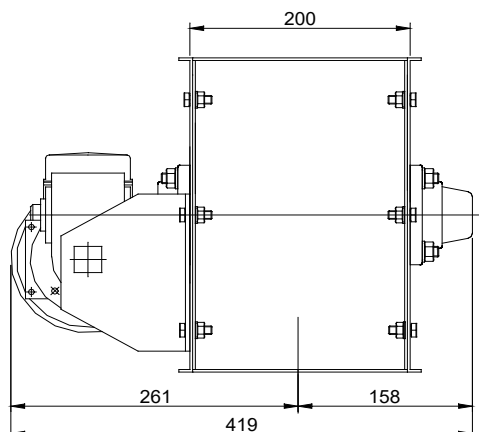
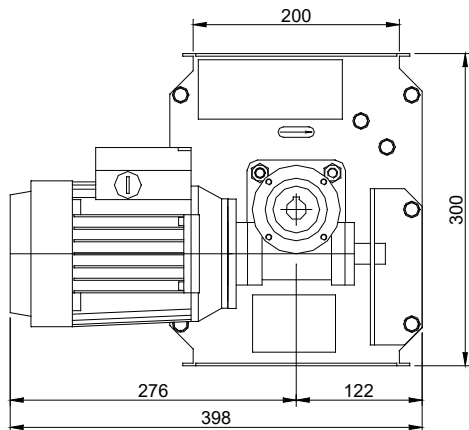

Installation

The air-lock valve is designed for mounting directly on the Cimbria Q-20 spouting system.

Technical data

Capacity	4 litres per RPM 10 m ³ per hour
Motor Power	0.37 kW (0.5 HK) 1.3 Amp, 400 V
Revolutions	1 400/40 RPM/min.
Gear Box	BJ 01/M4-30/85 ø20
Approx. weight with motor	30 kg
Approx. volume incl. sea-worthy packing	0.1 m ³
Inlet size (square)	200 mm (8") Q-20