

# MULTI CRUSHER TYPE CMC2

## GENERAL

Brand	Cimbria
Designation	Multi crusher
Model	CMC2
Use	Industry
Application	Can be implemented at an early stage in a conveying installation to protect the subsequent equipment in a processing line.

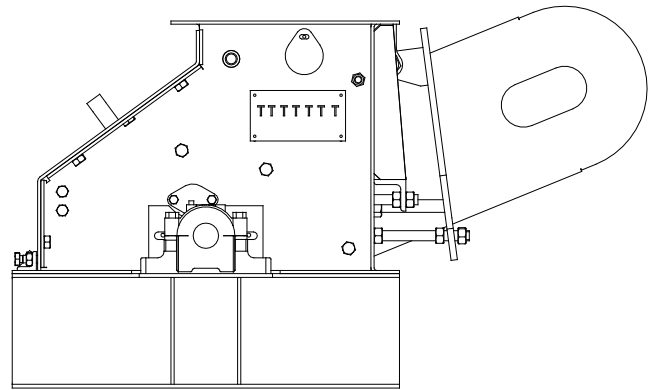
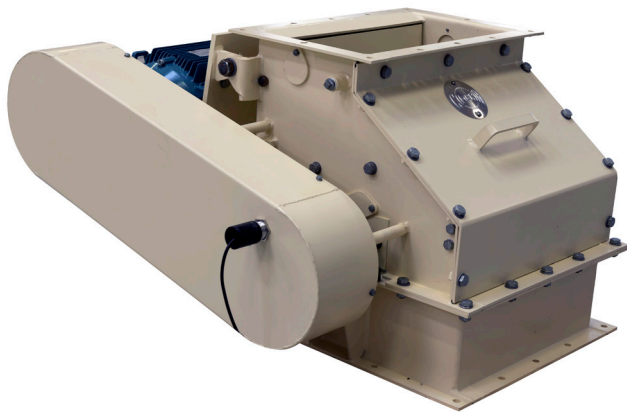

## Technical information

Built-in height	Total height of machine Inlet, inside dimensions Bottom outlet, inside dimensions Total width with motor Total length with motor	588 mm 460 x 270 mm 570x460 mm 1 050 mm 785 mm
Material	All manufactured in AISI 304 Surface treatment: Pickled, bearing housings chemical nickel Except: Motor, V-belts and flat bar beaters All manufactured st. 37 but all wearing surfaces in Hardox 400 Surface treatment: Cleaned and degreased. Cm primer 120 µ. Color RAL 9010 off white. Except: Motor, V-belts and flat bar beaters	
Capacity	Approx.: 10-40 m <sup>3</sup> depending on material	
Motor sizes	Standard: 7.5 kW motor Available motor sizes for standard Multi crushers: 11 kW standard motor 15 kW standard motor 18.5 kW standard motor 22 kW standard motor	
Description	The crusher is made from 5 mm sheet as a profile shaped machine body. The bottom frame is built as a U-profile. There is a 50 mm wide flange around the inlet with Ø10 mm holes. The machine is fitted with a service/inspection door at the front. The crusher is an impact crusher type equipped with 1 turned rotor, ø252x809 mm with ø60 mm steel shaft running in SKF ball bearings, type SNL 513. 3 sets of calibrated flat bar beaters Hardox 400 are fitted on the rotor, which crush the material against an adjustable plate during rotation. Driving station: 18,5 kW electric motor, 1400 t/min. - 3x380 V / 50 Hz. via shielded V-belt drive, gear ratio 1:1, direct to rotor. The Multi crusher is equipped with an adjustable, removable bottom grate with holes Ø6-Ø10. Equipped with tightening ring between crusher housing and shaft. The Multi Crusher can be approved for ATEX zone 22	
Accessories	Shaft speed guard / two indicators PTN 100 in house ATEX approved for zone 22 Food approved (AISI 314) Indicator on bearings Various hole sizes in the bottom grade Ø6-Ø10	