

MODUFLEX LOADING CHUTE K400

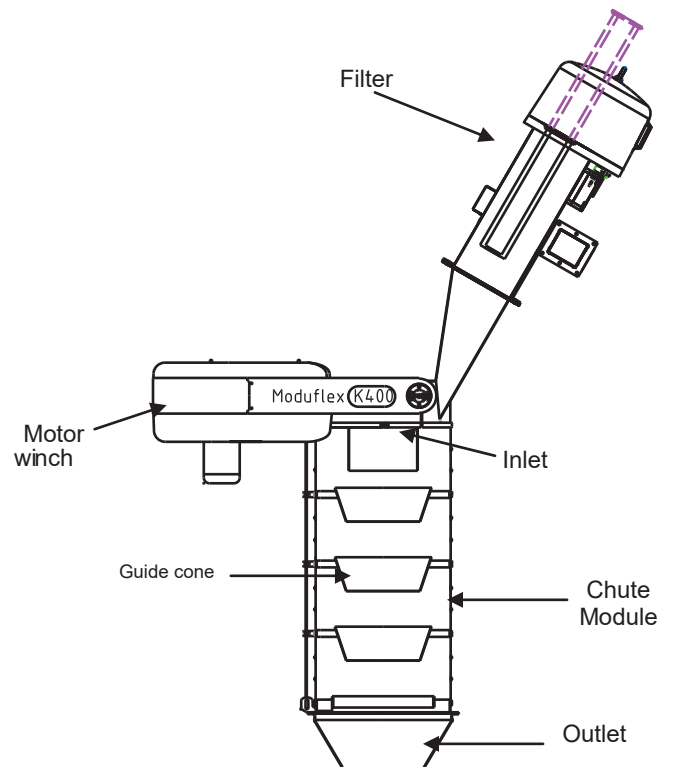

Technical information K400	
Inlet	Cylindrical Inlet tube in 2 mm steel. Fitting Ø400 PN10 flange (DIN 2576B). Mounted with 16 off M24 bolts Sidemounted filter module with built-in cartridge filter, pressure tank, magnetic valves etc. 9 off filter cartridges, totals 9 m ² , alternatively 14m ² or 18m ² . Fan with 0,75kW motor.
Chute Modules	Type Y - Standard: Yellow. PVC/Polyester. Ø700mm/H=300mm. Temperature -35°C - +70°C Type M - Food Grade: Light Grey. PVC/Polyester. Ø700mm/H=300mm. Temperature -30°C - +70°C Type W - Special: Misc. PVC/Polyester. Ø700mm/H=300mm. Temperature -35°C - +70°C Type B - Heavy Duty: Black. Synthetic rubber. Ø700mm/H=300mm. Temperature -40°C - +130°C Type G - Extreme Temperature: Grey. Teflon/Fiber glass. Ø700mm/H=300mm. Temperature -35°C - +260°C Type R - High Temperature: Red. Polyester and fiber/silicone rubber. Ø700/H=300. Temp. -40°C - +150°C (peak +220°C) Type Z - Low temperature: Green. PVC/PU. Ø700mm/H=300mm. Temperature -60°C - +70°C. Connection ring in stainless steel Aisi 304, c/w 3 off wire guides in nylon.
Guide Cones	Type O - Support ring. Steel, H=30mm Type J - Steel Standard. Steel, H=150mm, pt=2mm.
Outlet	Type T - Tank Outlet with steel cone for loading in tanker truck. Type F - Flat Outlet with dust skirt for loading in open truck. Type M - Multi Outlet with steel cone and dust skirt for loading in tanker truck and open truck.
Motor Winch	Motor 0.55-2.2 kW, 1400 rpm. Gear box ratio 100:1. Tight and slack wire indication External 3-point wire hoist system with high precision ball bearings and 3 off winch discs vertically fitted. Hoist wires Ø5mm available in steel, stainless steel Aisi316 or Long Life steel quality. Self-lubricating wire rollers in Ertalite TX, alternatively steel/stainless steel with bronze bearing
General info	Max. loading capacity approx. 440 m ³ /hour. Compressed air supply, clean and dry for filter: Connection 5-6 bar. Filter cleaning air consumption 100-150 NL/min. Pressure air connection ½". Metal parts available in painted steel st. 37 or stainless steel Aisi 304. Other steel qualities on demand. Surface treatment St. 37: Iron phosphating, 80 micron coating RAL 9010 pure white. Surface treatment Aisi 304: Acid-washed without any further treatment Motor winch covers in ABS - RAL 6005 dark green. Cover on filter RAL 6005 Available with full approval and certificates for location in ATEX zone 21 and 22 (zone 20 inside the chute)

Accessories for loading chute K400 please see separate Data Sheets.

MODUFLEX LOADING CHUTE K400

K400									
	Outlet type TS			Outlet type FS			Outlet type MS		
Cone	Steel			Steel			Steel		
M	L1	L2	L3	L1	L2	L3	L1	L2	L3
1	796	534	262	810	548	262			
2	1103	579	524	1117	593	524			
3	1410	624	786	1424	638	786			
4	1717	669	1048	1731	683	1048			
5	2024	714	1310	2038	728	1310			
6	2331	759	1572	2345	773	1572	2630	1058	1572
7	2638	804	1834	2652	818	1834	2937	1103	1834
8	2945	849	2096	2959	863	2096	3244	1148	2096
9	3252	894	2358	3266	908	2358	3551	1193	2358
10	3559	939	2620	3573	953	2620	3858	1238	2620
11	3866	984	2882	3880	998	2882	4165	1283	2882
12	4173	1029	3144	4187	1043	3144	4472	1328	3144
13	4480	1074	3406	4494	1088	3406	4779	1373	3406
14	4787	1119	3668	4801	1133	3668	5086	1418	3668
15	5094	1164	3930	5108	1178	3930	5393	1463	3930
16	5401	1209	4192	5415	1223	4192	5700	1508	4192
17	5708	1254	4454	5722	1268	4454	6007	1553	4454
18	6015	1299	4716	6029	1313	4716	6314	1598	4716
19	6322	1344	4978	6336	1358	4978	6621	1643	4978
20	6629	1389	5240	6643	1403	5240	6928	1688	5240
21	6936	1434	5502	6950	1448	5502	7235	1733	5502
22	7243	1479	5764	7257	1493	5764	7542	1778	5764
23	7550	1524	6026	7564	1538	6026	7849	1823	6026
24	7857	1569	6288	7871	1583	6288	8156	1868	6288
25	8164	1614	6550	8178	1628	6550	8463	1913	6550

K400 + FlexClose + indicator							
Rotating+ capacitive indicator					Vibration rod		
M	LC	L1	L2	L3	L1	L2	L3
2	1197	1667	1148	519	1737	1218	519
3	1504	1974	1193	781	2044	1263	781
4	1811	2281	1238	1043	2351	1308	1043
5	2118	2588	1283	1305	2658	1353	1305
6	2425	2895	1328	1567	2965	1398	1567
7	2732	3202	1373	1829	3272	1443	1829
8	3039	3509	1418	2091	3579	1488	2091
9	3346	3816	1463	2353	3886	1533	2353
10	3653	4123	1508	2615	4193	1578	2615

K400 with FlexClose no indicator					
M	LC	L1	L2	L3	
2	1197	1507	988	519	
3	1504	1814	1033	781	
4	1811	2121	1078	1043	
5	2118	2428	1123	1305	
6	2425	2735	1168	1567	
7	2732	3042	1213	1829	
8	3039	3349	1258	2091	
9	3346	3656	1303	2353	
10	3653	3963	1348	2615	

K400 with Flexfill					
M	LC	L1	L2	L3	
3	1784	2103	1317	786	
4	2091	2410	1362	1048	
5	2398	2717	1407	1310	
6	2705	3024	1452	1572	
7	3012	3331	1497	1834	
8	3319	3638	1542	2096	
9	3626	3945	1587	2358	
10	3933	4252	1632	2620	

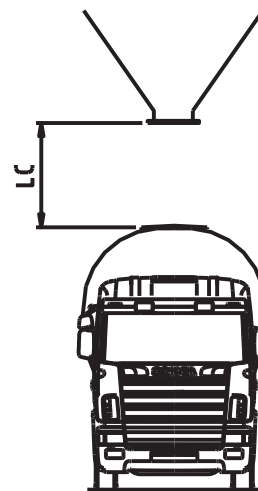
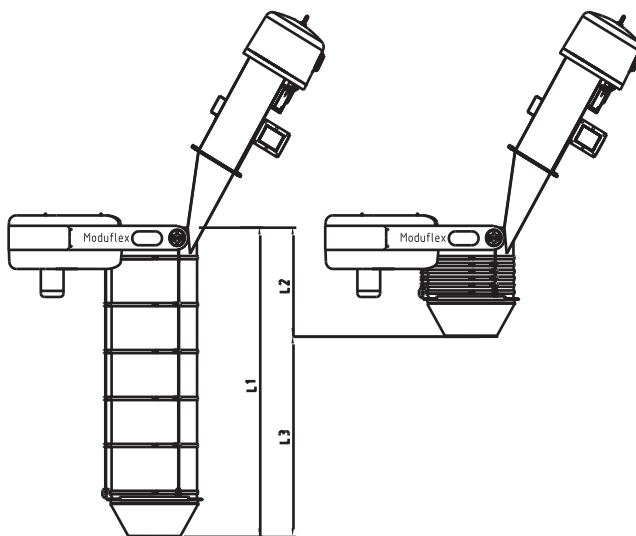

LC measure to be used when the loading chute is fitted with FlexClose or FlexFill.