

Data Sheet 74.2a

CYCLOFAN Technical Data Type CF10, 15, 20 & 30

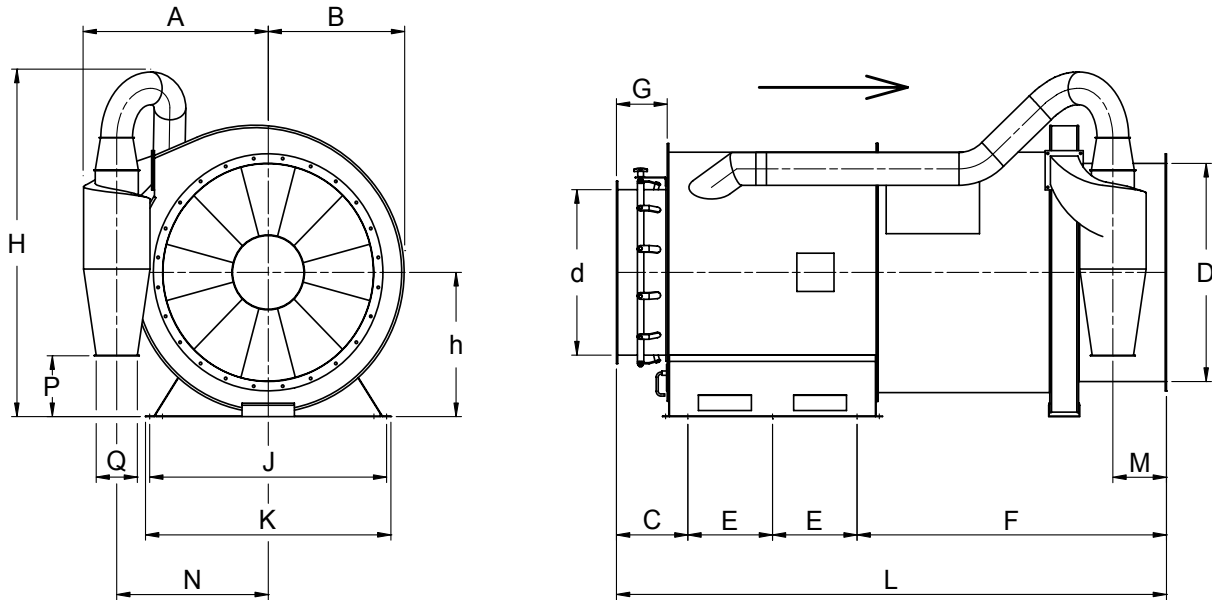

Figure 1: Measurements



Type	A	B	C	d	D	E	F	G	h	H	J	K	L	M*	N	P	Q
CF10/15	805	570	222,5	ø600	ø850	300	1402	150	590	1470	950	990	2224,5	218	647	158,5	ø200
CF20/30	875	645	337,5	ø750	ø1000	400	1462,5	240	660	1590	1120	1160	2600	253,5	716	279	ø200

* Depending on Mini Cyclon

Assembly

The Cyclofan can be installed both horizontally and vertically, as the position has no effect to the degree of separation.

Noise Level

Compared to an ordinary fan, with a similar capacity and a static pressure that allows connection of a cyclone, the cyclofan is relatively silent.

Further noise reduction to comply with local regulations can be achieved by mounting a Cimbria silencer.

Table 1: Noise level dB(A)

Hz	63	125	250	500	1K	2K	4K	8K
CF 10	70	81	84	91	93	93	84	76
CF 15	71	82	86	93	94	92	86	78
CF 20	73	86	92	98	102	100	93	84
CF 30	82	93	101	104	102	102	97	88

Altitude above Sea Level

As other fans the capacity of the Cyclofan is also dependent on the pressure. Operation in altitudes above 500 meters will reduce the capacity of the Cyclofan. If this is the case, then please contact Cimbria for further information.

Capacity curves and dust separation efficiency

Capacity curves and the dust separation efficiency of the 4 models of Cyclofans are shown in diagrams 1 and 2.

Diagram 1: Capacity

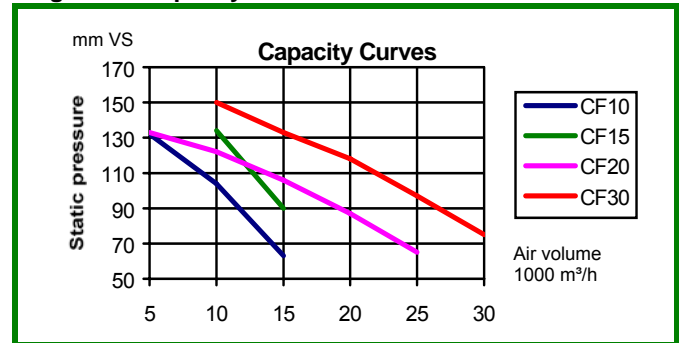
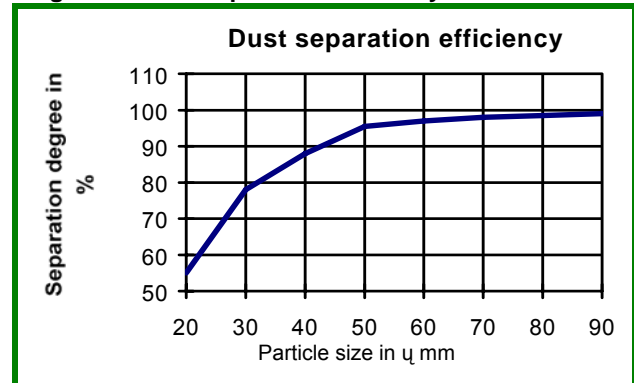

Diagram 2: Dust separation efficiency



Copyright © - The right to alterations is reserved