

Datasheet 26.1

Air-lock valve type QDG-92



Application

CIMBRIA's air-lock valve type QDG-92 is used for discharge of dust and other separated particles from systems working with vacuum or pressure. It is dust proof and is used as a pressure block between a cyclone and a dust collecting bag.

In connection with CIMBRIA's dust collecting cyclofans the air-lock valve is mounted between the bottom outlet of the mini cyclone and the dust bag, where it ensures a uniform and continuous discharge of dust and other particles, and at the same time minimises the air escaping through the outlet into the dust bag.

Design

The air-lock valve is manufactured from galvanised plate and is complete with a 300 (12") steel roller with 6 radial vanes of oil-resistant rubber. The rotor is suspended in ball bearings and the gear motor is mounted on the extended axle of the rotor.

The air-lock valve is lubricated for life is designed for continuous operation.

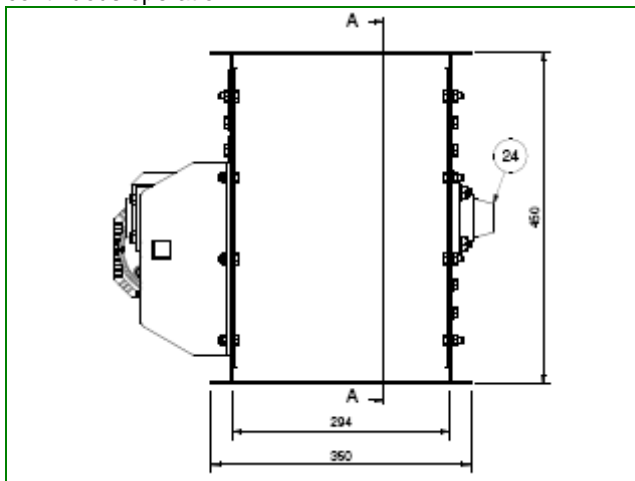
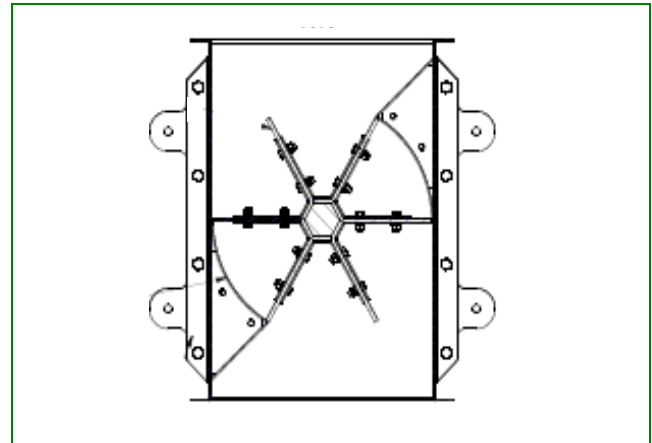

Installation

The air lock valve is designed for mounting directly on the Cimbría Q-30 spouting system.

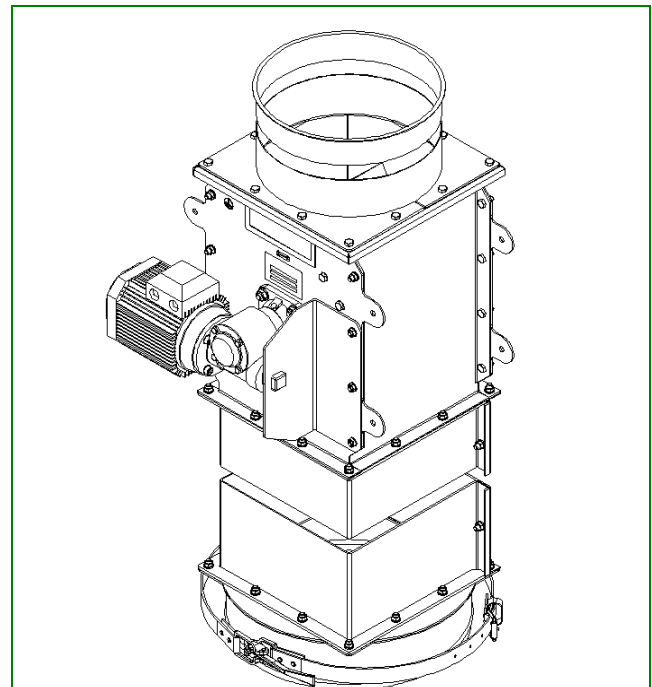

TECHNICAL DATA

Capacity	19,2 litres per RPM. 48 m ³ per hour.
Motor	0,37 kW (0,5 HK) 1,30 Amp, 400 V
RPMs	1400/40 rpm./min.
Gear	BJ 01/M4-30/85 ø20
App. Weight with motor	45,8 kg
App. Volume incl. seaworthy packing	0,17 m ³
Size of inlet (square)	300 mm (12") Q-30

Copyright © - Right to alterations reserved