



DANTOASTER

DTF 30/9000

GENERAL

Brand	Cimbria
Designation	Dantoaster
Model	DTF 30/9000



Toxins in Foodstuffs

Micro-organisms and their waste products in foodstuffs constitute today a large problem for human beings and animals all over the world. Salmonella in chickens, aflatoxin in dried fruit as well as ochratoxins in pig feed are examples from the current debate. The Dantoaster utilises a high temperature method of drying known as HTST (High Temperature Short Time). The temperature of the air led into the system is usually between 800° and 1000°C, and the product is heated by the air stream in the rotating drum. The processing time can be varied from 1 to 10 minutes.

Dantoaster Feed Processor

Dantoaster's well-known Feed Processor System is used increasingly – in Denmark as well as in other countries - as a high capacity and "low cost" technology for heat treatment and preservation within the foodstuff industry. The effect of this treatment is to minimise the food-based infection of our foodstuffs, raise the quality and to improve the nutritional value to the benefit of both producer and consumer.

Drying

The Cimbria Dantoaster is well-suited for drying of grain and similar products that have a high water content and where changes in the product's quality (e.g. germination capacity) is not critical.

Sterilisation

The sterilisation process alters neither the grain's shape nor size. The shell remains intact, but any germs present are killed. Sterilised grain can safely be stored for a long time in an unventilated storage facility, since no respiration takes place in storage because the seed germs are all dead.

Gelatinisation

Gelatinisation involves boiling the starch. In the gelatinisation process itself, the crystalline structure of the starch grain is partially broken down. This makes the starch soluble, more digestible (more easily accessible for digestive enzymes), and therefore better suited for the production of feed pellets.

Toasting

The term "toasting", as used in the animal feed industry, relates to an intensive heat treatment aiming to inactivate nutritionally undesirable substances. Such substances in soya, for example, make the raw soya beans unsuitable for feed. Heat treatment inactivates these substances, making Soya an excellent feed with high levels of protein and fat. Similar problems which can be solved in the same way exist in other products, including rape and peas.

Conditioning

The Cimbria Dantoaster is widely used as a conditioning unit prior to rolling cereals, for example. Its advantages in this context include low energy consumption and high capacity. It also renders a steam unit superfluous.

Innumerable Applications

The system can be used for heat treatment of practically all-flowing and paste-like products for human consumption. The possibilities are innumerable:

- Drying of barley, wheat, rape and peas for use in feed.
- Germ inactivation of grain.
- Gelatinisation of starch grain.
- Toasting of Soya beans.
- Germ inactivation of food-fibre products.
- Conditioning of maize, peas and soya beans without rolling.
- Protein protection.



DANTOASTER

DTF 30/9000

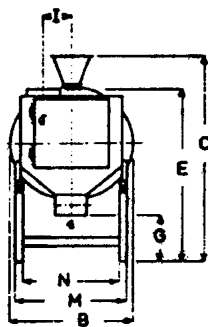
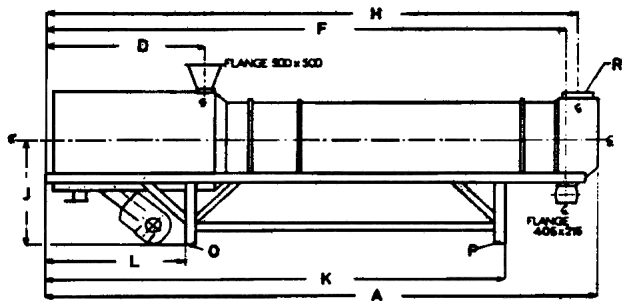

DTF-dimensions all i mm.

Type	30/9000
A	8 250
B	1 600
C	2 925
D	2 350
E	2 410
F	7 760
G	590
H	7 950
I	365
J	1 685
K	6 880
L	2 110
M	1 460
N	1 260
O raise	0-350/2.5 ton
P turn	/1 ton
R	450∅
Weight max.	7 ton

Type DTF	30/9000
Caloric consumption kW	1 500
Evaporative capacity kg/h	1 500
Energy consumption Kcal/kg H ₂ O	800 - 900
Drying capacity ton/h barley 20% - 16% (intake cap.)*	30
Air consumption v/100°C m ³ /h	10 - 11 000
Drum motor kW	7.5
Burner motor kW	2.6
Sluice motor kW	0.55

*After correct cooling