

CHAIN CONVEYOR TYPE RS

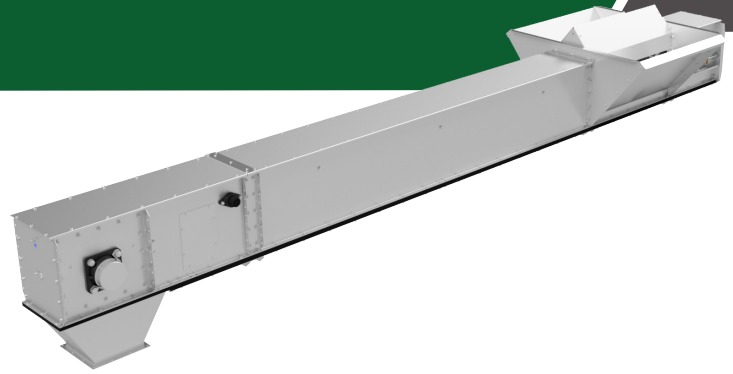

GENERAL

Brand	Cimbria
Model	RS Chain Conveyor
Capacity range	72–212 m ³ /h
Chain speed	up to 0.60 m/s
Application	Moving dry bulk materials, such as grains, pulses and pellets

Cimbria type RS chain conveyor is designed for moving dry bulk materials, such as grains and grain-like products, but can successfully be used to transport other materials, such as granulate, shavings etc. Cimbria will assist with consulting.

Scraper flaps are bolted onto the chain's flights to move material, to clean the bottom of the conveyor, and to protect the chain from wear.

The chamfered profile is ideal for conveying tasks with frequent change of materials that have a low tolerance to mixing.

FEATURES

- Single bottom casing with return rollers
- Dual-side or top loading
- Single strand conveyor chain, pins-and-bush assembly; data sheet: *Conveyor Chain*
- Welded flights with bolted scraper flaps
- Manual chain tensioning at tail end
- Wear plates on bottom

DRIVE SYSTEM

- Parallel shaft helical gearmotor, hollow shaft
- Gearmotor mounted on right or left hand side as specified

CONTROLLERS

- Overflow sensing
- Rotation sensing (optional)
- Bearing heat sensing (optional)
- Explosion relief (optional); data sheet 50

ACCESSORIES

- Air cleaning system for tail end
- Outlet for Q-pipe system
- Top covers for inlet sections
- Inspection windows
- Sun cover for gearmotor
- Support system; data sheet: *Chain Conveyor Support System*

Technical data

Maximum capacity	RS-3	72 m ³ /h
	RS-5	119 m ³ /h
	RS-7	161 m ³ /h
	RS-8	212 m ³ /h
Maximum bulk density	850 kg/m ³	
Drive motor size	According to application	
Chain speed	Up to 0.60 m/s	
Sound pressure level	75 to 85 dB(A)	
Maximum length and angle of slope	Depends on the material properties and the length and angle of the conveyor	
Operating conditions	Indoor and outdoor	
	-15°C to +40°C ambient	

NOTE: All capacities in the above table are based on the handling of dry and cleaned wheat.

Materials

Casing	Standard	Pre-galvanised steel	
	Optional	Hot-dip galvanised steel	
		Stainless steel	
		Painted steel	
Wear plates, bottom	PE-UHMW, antistatic, 10 mm		
Chain	Steel, oil coated		
Rollers	Standard	RS-3, -5	Nylon
		RS-7, -8	Steel, oil coated
	Optional	RS-7	Nylon (ø22 bush)
Scraper flaps	PE-UHMW, antistatic		

Compliance

Atex	Standard	Non-zone inside
	Optional	Non-zone outside
Zone 22 or 21 inside		
Zone 22 or 21 outside		

NOTE: Specific requirements apply for ATEX compliance.

CHAIN CONVEYOR TYPE RS

DIMENSIONS

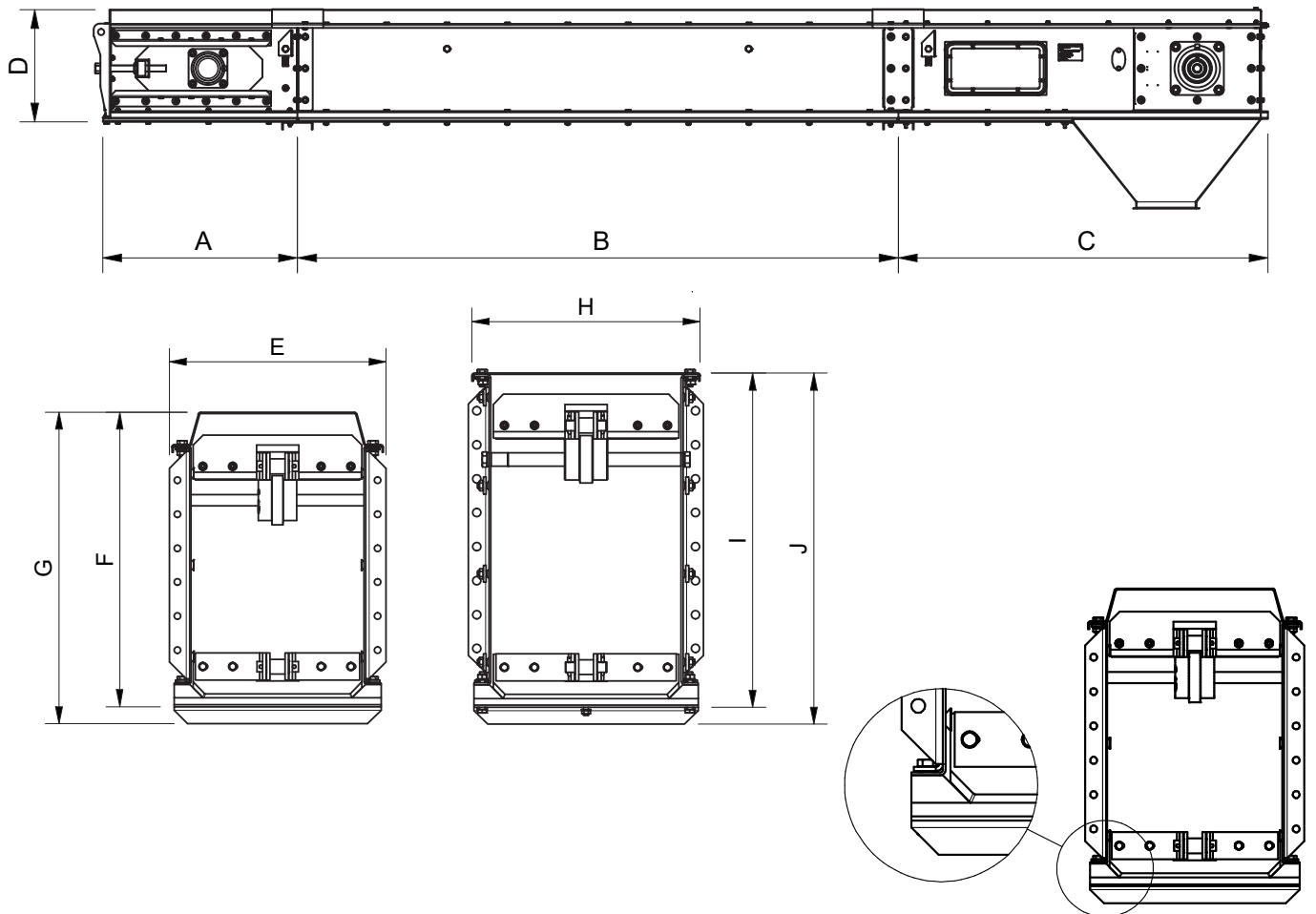

	A [mm]	B [mm]	C [mm]	D [mm]	E [mm]	F [mm]	G [mm]	H [mm]	I [mm]	J [mm]
RS-3	670	490 / 990 / 1990 / 3 000	1 225	372	265	374	399			
RS-5	670	490 / 990 / 1990 / 3 000	1 225	434	331	434	459			
RS-7	670	490 / 990 / 1990 / 3 000	1 225	492				336	492	517
RS-8	670	490 / 990 / 1990 / 3 000	1 225	530				404	530	560

	Grain layer thickness [mm]	Grain layer width [mm]	Thickness, top plate [mm]	Thickness, side plate [mm]	Thickness, bottom plate [mm]	Weight with material [kg/m]	Driving section [kg]	Intermediate section [kg/m]	Tension section [kg]
RS-3	180	205	2	2	3	70	60	35	58
RS-5	240	255	2	2	3	100	80	45	70
RS-7	290	280	2	3	3	140	120	70	110
RS-8	330	330	2	3	3	165	140	75	100