

# BUCKET ELEVATOR TYPE EH

## GENERAL

Brand	Cimbria
Designation	Bucket Elevator
Model	EH
Use	Industry
Application	Vertical transport of loose bulk materials, such as grain like products.



Cimbria type EH bucket elevator is designed for vertical transport of loose bulk materials, such as grain like products.

The EH elevator has a heavy duty construction. It is intended for installation in an industrial environment and can be used for large scale transport, with a long period of operation.

The EH elevator has a totally enclosed construction divided into modular sections consisting of a head section, leg section and a boot section.

## FEATURES

- Head pulley
- Boot pulley with slide plates
- Backstop, built in
- Slatted boot pulley with cone
- Slatted head pulley or solid head pulley with rubber lagging
- Weight tensioner

## DRIVE SYSTEM

- Helical bevel gearmotor, hollow shaft
- Gearmotor mounted on right or left hand side as specified
- Electrical soft starter  $\geq 15$  kW (highly recommended)

## CONTROLLERS

- Rotation sensing
- Bearing heat sensing (optional)
- Misalignment detectors (optional)

## ACCESSORIES

- Connection for negative pressure
- Equipotential bonding of shafts
- Explosion relief (ATEX configuration)
- Inlet module
- Outlet module
- Scraper for solid boot pulley
- Support system; data sheet: *Bucket Elevator Support System*

## Technical data

Machine	EH-20	EH-24	EH-32	EH-40
Maximum capacity	638 m <sup>3</sup> /h	737 m <sup>3</sup> /h	936 m <sup>3</sup> /h	1 209 m <sup>3</sup> /h
Minimum belt speed	3.00 m/s	3.00 m/s	3.00 m/s	3.00 m/s
Maximum belt speed	3.80 m/s	3.80 m/s	3.80 m/s	3.80 m/s
Maximum bulk density	850 kg/m <sup>3</sup>			
Drive motor size	According to application			
Sound pressure level	75 to 87 dB(A)			
Operating conditions	Indoor and outdoor -15°C to +40°C ambient			

NOTE: All capacities in the above table are based on the handling of dry and cleaned wheat.

## Materials

Casing	Standard	Hot-dip galvanized
Casing wear parts (top and bottom)	Standard	Steel (Hardox®)
Belt material	Standard	Standard belt, 'Y', antistatic, (SBR)
	Optional	Oil-resistant belt 'GS', anti-static (NBR)
Belt fasteners	Standard	Steel
Buckets	Standard	Steel
	Optional	Plastic (PEHD)
Inlet wear parts	Standard	Steel (Hardox®)
Outlet wear parts	Standard	Steel (Hardox®)
Inlet hopper	Standard	Steel (Hardox®)

## Compliance

ATEX	Standard	Non-zone inside Non-zone outside
	Optional	Zone 22 or 21 inside Zone 22 or 21 outside

NOTE: Specific requirements apply for ATEX compliance.

# BUCKET ELEVATOR TYPE EH

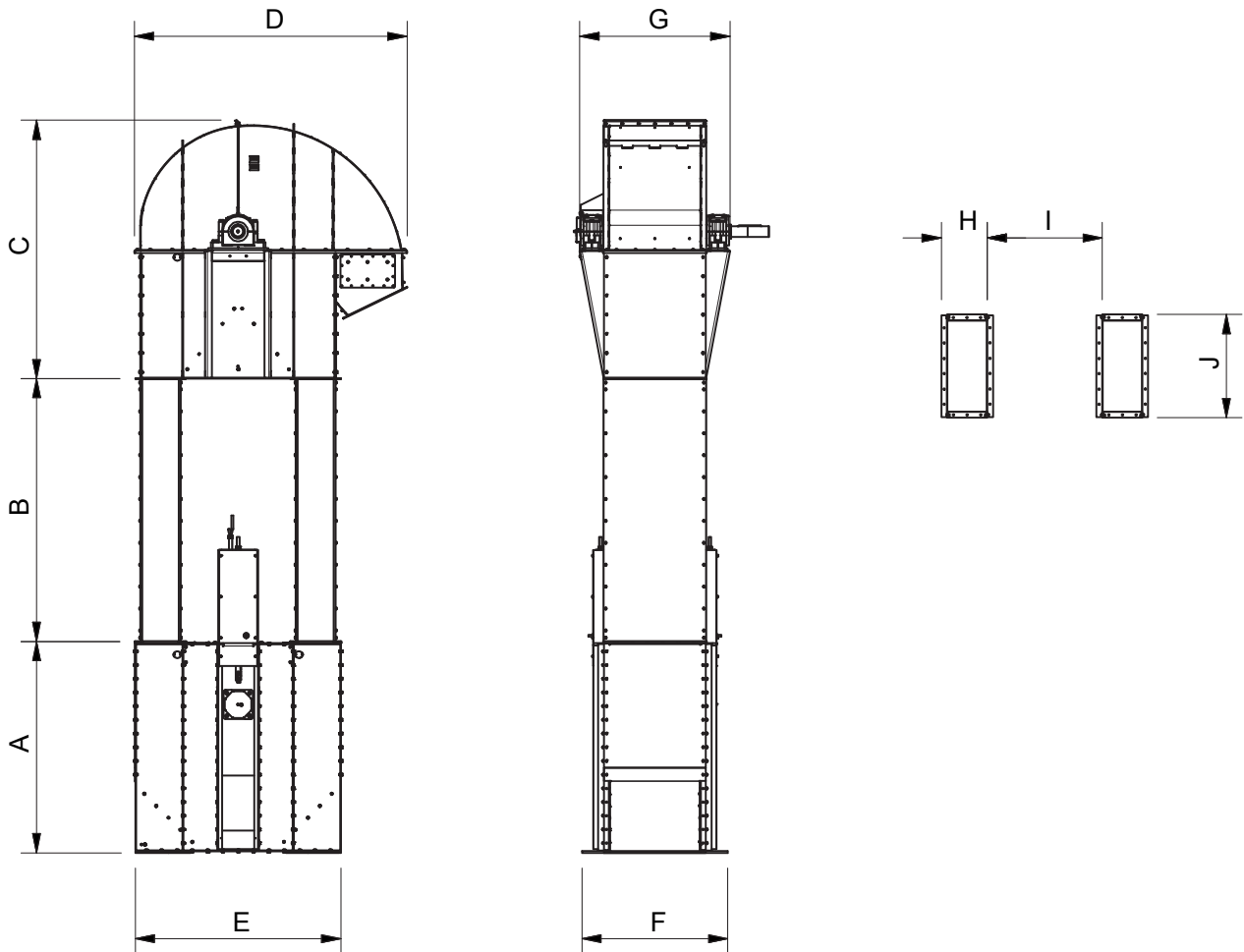

	A [mm]	B [mm]	C [mm]	D [mm]	E [mm]	F [mm]	G [mm]	H [mm]	I [mm]	J [mm]
EH-20	1 930	2 400	2 360	2 490	1 880	1 200	1 240	413	1 050	810
EH-24	1 930	2 400	2 360	2 490	1 880	1 330	1 370	413	1 050	940
EH-32	1 930	2 400	2 360	2 490	1 880	1 550	1 590	413	1 050	1 160
EH-40	1 930	2 400	2 360	2 490	1 880	1 700	1 740	413	1 050	1 310

	Boot section [kg]	Head section [kg] <sup>1</sup>	Leg section [kg/m elevator]	Belt [kg/m]	Weight of material [kg/m] <sup>2</sup>	Belt types				Belt width [mm]
EH-20	2 000	2 200	140	9.35–15.84	34	630/3 1+3	800/4 1+3	1 000/4 1+3	1 250/4 1+3	570
EH-24	2 100	2 300	150	11.56–19.58	43	630/3 1+3	800/4 1+3	1 000/4 1+3	1 250/4 1+3	700
EH-32	2 400	2 450	170	15.30–25.92	53	630/3 1+3	800/4 1+3	1 000/4 1+3	1 250/4 1+3	920
EH-40	2 600	2 600	190	17.85–30.24	68	630/3 1+3	800/4 1+3	1 000/4 1+3	1 250/4 1+3	1 070

[1] Weight of head section is without gearmotor

[2] With material bulk density 760 kg/m<sup>3</sup>