

MISALIGNMENT DETECTOR XY-81.AT2.13

Device description

The misalignment detector is a limit switch that detects belt misalignment in continuous handling equipment. Misalignment detectors are typically mounted in pairs across from each other at critical points along the conveying belt.

The misalignment detector stays energised during normal operation. As the belt moves to the side and pushes the plunger head, it engages the actuating mechanism. While the actuating mechanism is engaged, there is no signal. Depending on the situation, the control system may activate an alarm and automatically stop the controlled machinery. The misalignment detector automatically resets when the belt moves off the plunger head.

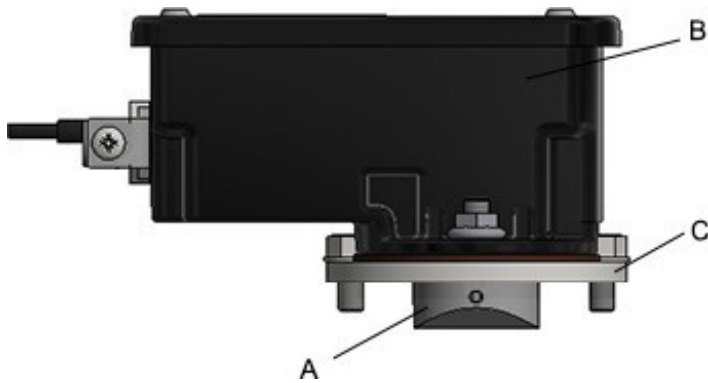

Figure 1: Main parts and their function

Key	Part	Function
A	Plunger head	Transfers belt displacement to the actuating mechanism
B	Plunger housing	Encloses the actuating mechanism
C	Mounting bracket	Secures the plunger housing to the mounting surface

Applications

The misalignment detector may be used with the following machinery:

Yes: May be used in the specified location.

No: Shall not be used in the specified location.

Type	Head	Tail	Tripper
Cimbria™ belt conveyor type GI	No	Yes ¹	-
Cimbria™ belt conveyor type GH	No	Yes ^{1,2}	No

¹ Maximum 500 mm from centre of pulley.

² GH-1200.

Specifications

Identifying characteristics in accordance with EN 60947-5-2.

Electrical data

Sensor operation (delivery status)		
Switching element function		DC, N.O.
Rated operational voltage	U_e	12 – 24 V DC
Operational voltage range	U_B	10 – 30 V DC
Rated insulation voltage	U_i	75 V DC
Rated impulse withstand voltage	U_{imp}	500 V
Voltage drop	U_d	≤ 2 V DC specification
Utilization category		DC 13
Rated operational current	I_e	200 mA ±10 %
Minimum operating current	I_m	1 mA
Off-state current	I_r	< 0.1 mA
No-load supply current	I_o	< 10 mA
Switching element		permanent overload and s.c.p.
Short-circuit protection		pulsed, current-limited and thermal
Frequency of operating cycles	f	450 Hz
False polarity protection		yes
Time delay before availability	t_v	< 300 ms

Environmental conditions

Ambient temperature	-20°C to +60°C
Relative humidity	Maximum 50% at +40°C. Higher relative humidities are permitted at lower temperatures (for example 90% at 20°C).
Atmospheric pressure	80 kPa to 110 kPa
Volume fraction of oxygen in air	21%
Altitude above mean sea level	Up to 1000 m
Pollution degree	Pollution degree 3
Level of housekeeping	Poor
Hazardous dust area class	Zone 21
Dust layer thickness	5 mm