

# INDENTED CYLINDER SEED PROCESSING



An expert  
at your side.



# The Experts in Seed Processing.

To find the right machines for your business you need a partner you can rely on. One who understands your business and offers expert advice during selection, installation and beyond. Cimbria has been helping customers succeed for more than 75 years, with extensive know-how and technologically advanced solutions for the entire process of cleaning grain, seed and food commodities.



## Grading with Care.

Mechanical separation by indented cylinders is used for **grading** any granular material such as wheat, oats, fine seeds, lentils by length and for **separating seeds from stalks and other long or short straws**.

If your crops need special attention to separate foreign bodies at the cleaning stage of processing, Cimbria Indented Cylinders are the solution. They can be used alone or **set in series to accomplish different jobs** identifying different types of impurities.



# Indented Cylinder Separators.

Used for length grading of all granular materials, such as wheat, oat, maize, rice, fine seeds, lentils, sticks from sunflower or sugar beet, plastic particles, etc., as well as for the extraction of unwanted short or long admixtures.



## HSR 1010-16010 R/L

Round grain/long grain cylinder



## HSR 1010-16010 R-RN/L-LN

Round grain/long grain cylinder with regrader

## Principles of operation.

It consists of a horizontal rotating cylinder which has indents on the inside surface.

Through the inlet housing, the granular material to be graded flows into the interior of the rotating cylinder. The grains that embed themselves into the indents, will be lifted, will fall into the trough (after a certain distance based on your parameters) and discharged by a conveying screw.

The longer grains remain in the cylinder- shell and will be discharged separately.

The size of grains can vary between 1.0 mm and 24 mm.



### HSR 1020-16020 R-L

Round grain and long grain cylinder battery



### HSR 1030 16030 R L RN LN

Flour mill separator with round grain and long grain regrador

## Working in series.

Every cylinder features one single indent shape, however indents can be of many different sizes and shapes. So for different separation needs, the shells need to be changed or more than one cylinder can be connected to select different shapes in one time.





# Construction and Function.

## 01. SHELL

The inside cover is equipped with round or tear-drop shapes indents where kernel to be selected fit precisely.

## 02. DESIGN

The round, fully-closed housing is unique. Its design facilitates easy access to the cylinder segments. When the protective hood is opened, the machine is stopped automatically by a safety switch.

## 03. EXCHANGE OF SEGMENTS

The cylinder shell is divided into several segments and provided with quick-release catches. This allows a simple and fast exchange of the grading segments. On request, the segments can be equipped with cleaning doors.

## 05. LONG PRODUCT OUTLET

Kernels longer than the indent diameter will immediately slide out and remain on the inside surface of the indent cover, so to be discharged into the outlet housing.

## 04. SHORT PRODUCT OUTLET

The grains that embed themselves into the indents, will be lifted and after a certain distance (adjustable to suit) will fall out of the pockets under gravity into the trough.

## 06. TROUGH SEALING

All separator types are sealed between the trough and the cylinder shell. This prevents unwanted grains from getting into the trough and ensures even more precise grain separation.

## 07. DRIVES

No chain drives, belt drives or gearwheel drives are used in our grain separators, which guarantees considerably smoother operation. We only use top-of-the-line geared motors. Adjustable speed is offered as an option.



### 08. CHECKING THE SEPARATION

Two large inspection windows on the outlet side enable the operator to check the correct setting of the separator during operation, with no risk of accident.

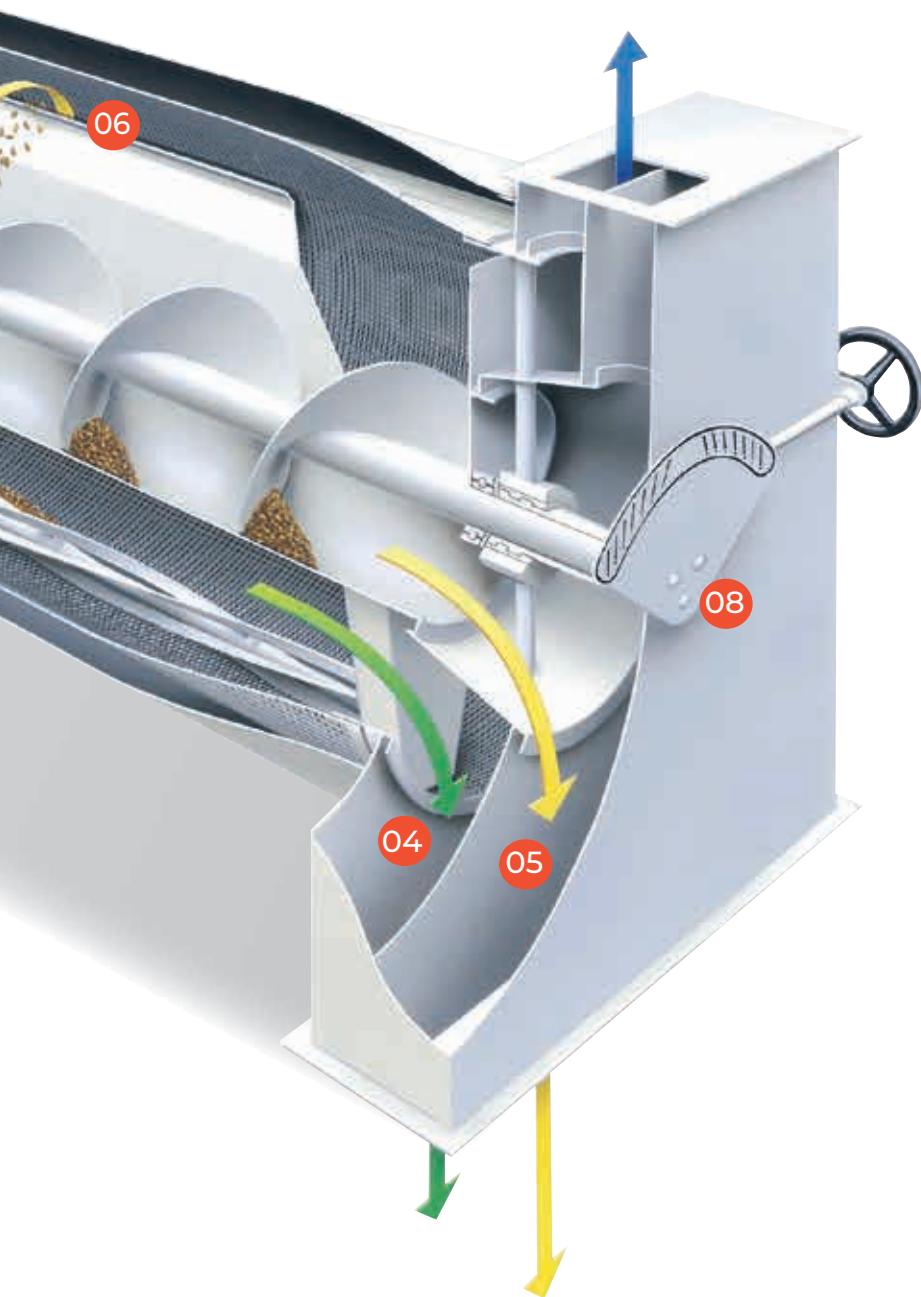

## OPTIONAL EQUIPMENT

### PNEUMATIC CLEANING

A compressed-air cleaning system which ensures faster emptying of the pockets and prevents a decline in the separator's output is available **on request**.

### CYLINDER INCLINATION

We supply adjustable inclination packages (0°-3°) or fixed inclination packages. This further optimises the separation results.

### STIRRING DEVICE

For heavily flowing products such as grass seeds or rice, we recommend the installation of our stirring device, which significantly increases the efficiency and output of the separator.

### WEAR RESISTANT LINING

For processing particularly abrasive products we can line neurlgic parts inside the machine with an exchangeable wear-resistant covering.

### ADJUSTABLE SPEED

Geared motors are available with mechanical or electronic speed control.

### AUTOMATIC TROUGH ADJUSTMENT

The trough regulation system can be equipped with adjusting motors.

### SPLITTING FEATURE

By splitting the grain flow we are able to achieve an outstanding max output of 45 t/h with our separator type HSR16010.

# Typical Flow Charts.

Cimbria indented cylinders can work in series, focusing on different results so to maximize product sorting.

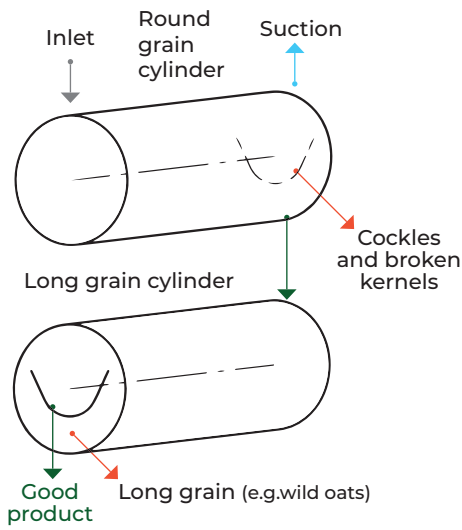

INDENTED CYLINDERS IN SERIES ARRANGEMENT

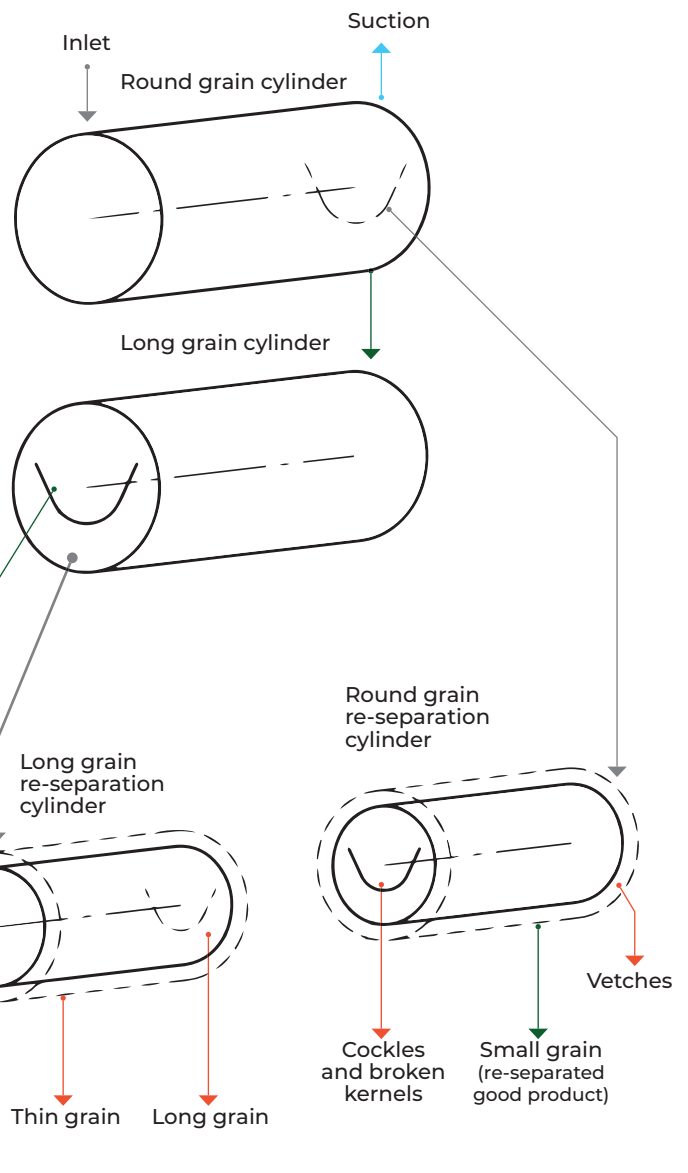

INDENTED CYLINDER BATTERY FOR FLOUR MILLS

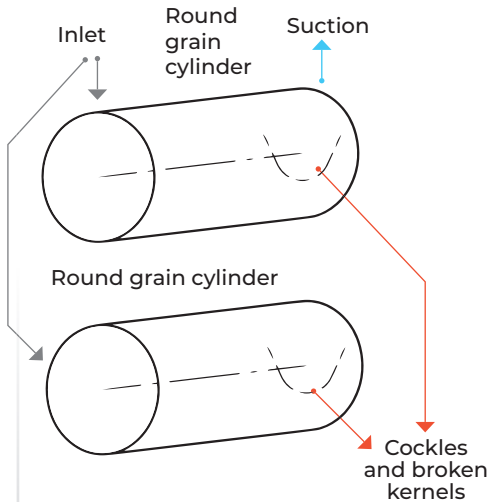

INDENTED CYLINDERS PARALLEL ARRANGEMENT



# Cylinder Shells.

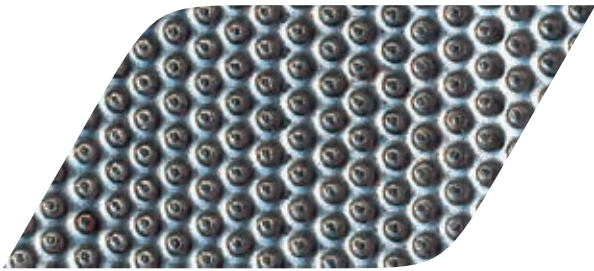

**Cimbria**

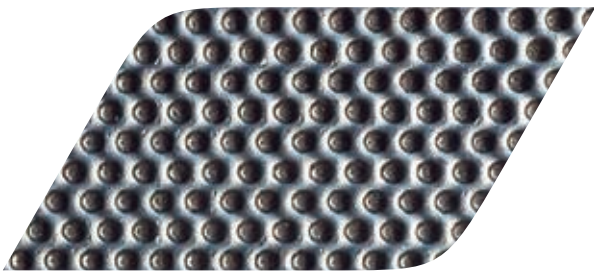

**Others**

## **HARDENED SEGMENTS**

On request, we will supply hardened segments which have a far longer service life and can be used for processing particularly abrasive products.



The cylinder shell is the most important part of the separator. The quality of the separation and the quantity of the waste depends on the construction of the cylinder. For this reason, we place special importance on the quality and workmanship of its construction.

## **CYLINDER SHELL**

Cimbria is one of the few manufacturers of grain separation cylinders which fabricates its own cylinder segments. This allows us to fulfill special customer requirements.

We have minimised the distance between the individual pockets in order to achieve the highest possible number of grading pockets per cm<sup>2</sup>. We can therefore provide a higher sorting output and better separation quality than our competitors.

The staggered arrangement of our pockets increases the service life of the segments.



Spherical pockets

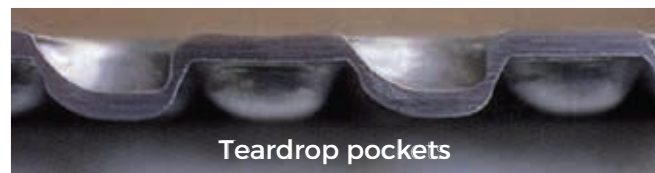

Teardrop pockets

## **POCKET SHAPES**

We offer spherical and teardrop pockets depending on the product to be sorted and on the grading task. This enables us to optimise the grading quality and to minimise waste.



# Testing Center.



SCAN THE QR  
TO SET UP  
YOUR TRIAL

## PUT US TO THE TEST

Send us your toughest sorting challenge. Cimbria's multiple testing centers are available for customizable lab trials worldwide. Let our experts recommend the best solution for your business.



Grains



Pulses



Food



Seeds

# Quality Control.

During the manufacturing process, each machine as well as its components must pass several strict quality controls to meet our customers' requirements at the highest level. Before dispatch, a final quality control process following a sophisticated checklist is carried out, rounded off by a 24-hour test run. We can thus guarantee that each machine is ready to operate at the customer's site very quickly and without any surprises.

# Our Services.

## CERTIFICATIONS

- CE conformity certificate
- 2006/42/CE on machinery safety
- 2014/30/CE on Electromagnetic Compatibility

## DELIVERING RELIABILITY AND DEPENDABILITY

You are committed to delivering the highest quality for your customers. Cimbria can help you deliver. With our customer service team and partners we offer exclusive after-sales service, for qualified assistance at all times. Aftersales service not only includes spare parts service, but also regular maintenance services, plant check-ups and consulting services.

**CONTACT US:**  
**CIMBRIA.AFTERSALES@AGCOCORP.COM**

## MACHINE TECHNICAL DATA

HSR			LABOR	1010	2010	3010	4010	5010	6010	8010	10010	12010	16010
Dimensions	Length	mm	1200	1850	2850	2545	3045	3545	4045	3320	3825	4325	5325
	Width	mm	800	640	640	860	860	860	860	1202	1202	1202	1202
	Height	mm	1465	620	620	870	870	870	870	1240	1240	1240	1240
Cylinder dimension	Diameter	mm	400	400	400	600	600	600	600	900	900	900	900
	Length	mm	570	1000	2000	1500	2000	2500	3000	2000	2500	3000	4000
Technical data	Motor Capacity	Kw	0.37	0.37	0.55	1.1	1.1	1.1	1.1	3	3	3	4
	Air Requirement	m <sup>3</sup> /min	-	6	7	9	9	9	9	12	12	12	12
Capacity	Wheat	t/h	0.3	1	2	3	4	5	6	8	10	12	16
	Barley	t/h	0.25	0.8	1.6	2.4	3.2	4	4.8	6.4	8	9.6	12.8
	Rice (Paddy)	t/h	0.2	0.4	0.8	1.2	1.6	2	2.4	3.2	4	4.8	6.4
	Sugar beet seed	t/h	0.2	0.3	0.6	1	1.3	1.6	1.9	2.6	3.2	3.8	4.4
	Sunflowers (unhulled)	t/h	0.1	0.3	0.6	1	1.3	1.6	1.9	2.6	3.2	3.8	5
	Alfalfa	t/h	0.1	0.2	0.4	0.6	0.8	1	1.2	1.6	2	2.4	3.2



CHECK CIMBRIA.COM FOR MORE TECHNICAL INFORMATION.

Copyright © 2023 all rights reserved. Pictures and technical data herein mentioned are indicative only and can be subject to changes. CIMBRIA reserves the right to change designs and specifications without notice.



**Cimbria.com**

Release date: December 2023/EN

**CIMBRIA A/S**

Faartoftvej 22  
7700 Thisted  
DENMARK

Phone: +45 96 17 90 00  
cimbria.holding@agcocorp.com

**Cimbria Heid GmbH**

Heid-Werkstraße 4,  
2000 Stockerau,  
AUSTRIA

Phone +43 22 66 699  
cimbria.heid@agcocorp.com

Follow us   

**[www.cimbria.com](http://www.cimbria.com)**