

SCREW CONVEYOR TYPE SUH

Design

The through conveyor type SUH is a heavy duty industrial model, designed for horizontal or slightly ascending transport of sand, cinders and wearing powders.

The construction is a dust-proof steel construction with trough sections of 2 m., strong inner centre tube, flight of circular blanks

with completely welded on one side, SY-free- standing bearings and adjustable packing boxes with Teflon packings.

A principle of intermediate bearing is applied, ensuring easy replacement of the wearing parts. The material used for the bearing is bronze as standard.

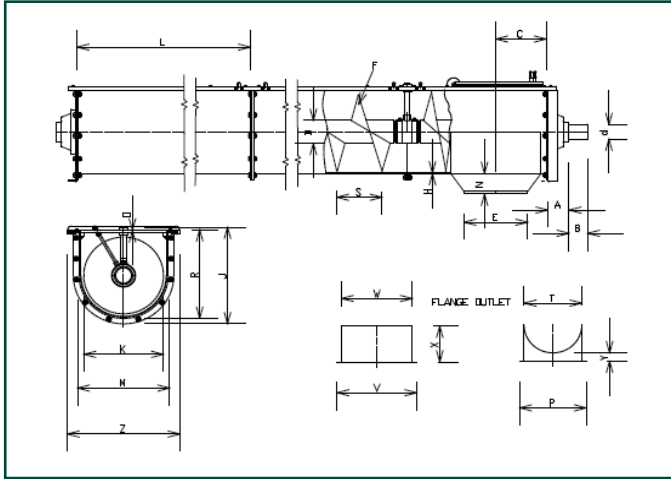

Conveyor type SUH - DIMENSIONS

DIMENSIONS								
	SUH 150	SUH 200	SUH 250	SUH 300	SUH 350	SUH 400	SUH 450	SUH 500
A	170	170	168	198	198	232	232	232
A1	172	172	172	204	204	234	234	234
B	90	90	92	131	171	201	201	201
C	207	207	257	258	283	307	332	356
d	35	35	35	60	60	80	80	80
D	88,9x4,9	88,9x4,9	88,9x4,9	114,3x5,4	114,3x5,4	114,3x5,4	114,3x5,4	114,3x5,4
D1	146	196	246	294	344	396	446	496
G	304	304	404	406	456	504	554	602
H	350	350	450	450	510	560	610	660
I	182	232	282	338	388	440	490	542
J	228	278	328	382	442	496	546	600
K	20	20	20	24	24	24	24	24
L	2000	2000	2000	2000	2000	2000	2000	2000
L1	5000	5000	5000	6000	6000	6000	6000	6000
M	162	212	262	314	364	416	466	516
N	183	233	286	341	391	442	492	543
O	270	320	370	424	504	558	608	662
P	224	281	328	382	447	499	549	601
S	130	175	225	260	305	315	335	390
T	2	2	2	2	2	2	2	2
T1	5	5	5	6	6	8	8	8
T2	5	5	5	5	6	6	6	6
Kg basic suppl.	40	54	68	105	130	170	195	215
Kg/m	38	50	60	80	90	120	130	145

All dimensions are in mm. Weights are excl. gear, motor and coupling

Conveyor type SUH - CAPACITY

CAPACITY	For every 5 degree ascent the capacity will drop 10%					
	Granulates etc.		Powders		Coarser products	
Type	Max rpm.	m3 / h with 50% filling and max rpm.	Max rpm.	m3 / h with 40% filling and max rpm.	Max rpm.	m3 / h with 30% filling and max rpm.
SUH 150	320	18	160	7	130	4,5
SUH 200	240	32	120	13	95	7,3
SUH 250	190	55	95	22	75	13,0
SUH 300	160	80	80	32	65	19,5
SUH 350	160	132	80	53	65	32,0
SUH 400	140	153	70	62	55	36,0
SUH 450	130	195	65	78	50	45,0
SUH 500	115	250	60	104	45	59,0

SCREW CONVEYOR TYPE SUH

Recommended effect diagrams for horizontal conveyor in standard version.

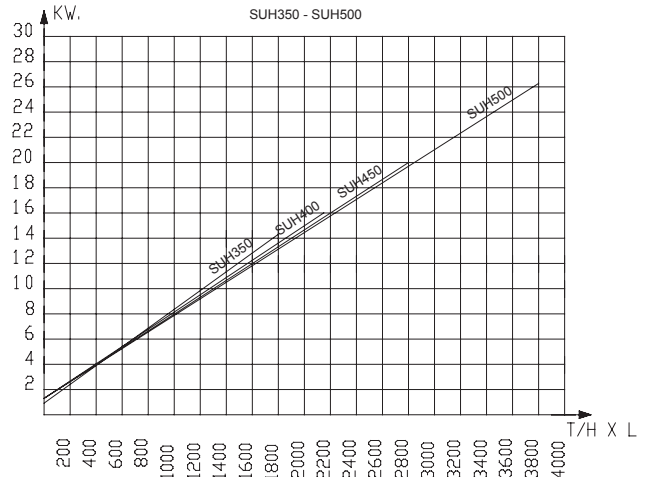
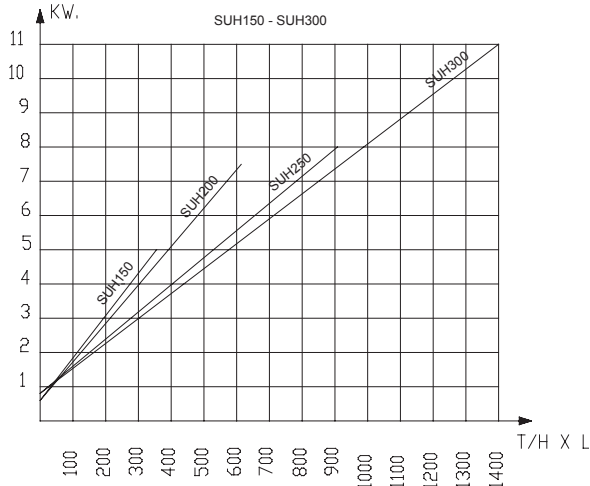

Flights can be delivered as right-hand or left-hand. As standard, the conveyors are delivered as right-hand.

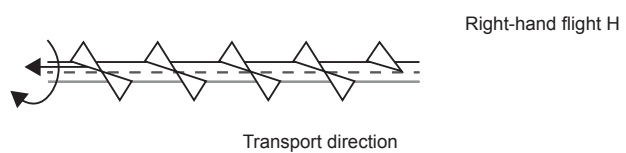
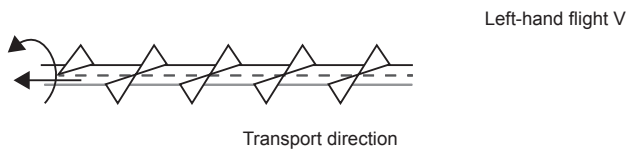

The diagrams apply for light powder products etc, effect factor 2,3. By strongly wearing material, such as sand, salt etc., effect factor 3-6 is used. By special conveyors and extraction conveyors under silos the diagrams do not apply. T/H = Tonne/hour - L= Length in meters

- Examples of effect factors:
- Effect factor 3,0 – Saw dust
 - Effect factor 3,5 – Coconut deposits
 - Effect factor 4,0 – Bone meal, cement, gypsum, earth, clay
 - Effect factor 5,0 – Fertiliser
 - Effect factor 6,0 - Ashes, cinders, sand, salt